

Standardtype

Ventil in Ruhestellung geschlossen -(NC).
 Der erregte Magnet öffnet direkt den Ventilsitz. Beachten Sie bei dieser Konstruktion, das der maximale Betriebsdruck nicht überschritten wird!
 Das Ventil schließt durch Federkraft.

Standard type

Valve non-energised closed by spring power - NC.
 When energised, the solenoid lifts the seal of the seat (orifice) directly. A pressure differential (Δp) is not required for the operation.



Steuerungsart: Type of control:	Direktgesteuert Direct acting	Metall. Innenteile: Metallic internals:	Messing und Edelstahl 1.4104 Brass and stainless steel (AISI 430F)
Konstruktion: Construction:	Sitzventil mit Tellerdichtung Poppet design	Einbauanlage: Installation:	nur mit stehendem Magneten actuator only in upright position
Anschluß: Connection:	Flansch DN15-DN250 Flanges DN15-DN250	Anschlußspannung: Supply voltage:	AC: 24,42,110,230V 50/60Hz DC: 24,110,205V=
Druck: Pressure:	0-max. 1,4 bar (s. Tabelle) 0-max. 1,4 bar (see table)	Spannungstoleranz: Voltage tolerance:	+5% / -10% +5% / -10%
Durchflußmedium: Medium:	neutrale, gasförmige u. flüssige Medien neutral, gaseous and liquid medium	Leistungsaufnahme: Power-consumption:	1702/3702 = 25 Watt 1322/3322 = 30 Watt 4242/5242 = 46 Watt 4272/5272 = 100 Watt 4352/5352 = 150 Watt 4402/5402 = 250 Watt
Viskosität/Viscosity:	22mm ² /s	Schutzart/Enclosure:	IP65 (nach/acc. to) DIN 40050
Mediumtemp./Medium temp.:	-10 bis/up to +80°C	Einschaltdauer/D.factor:	100% ED-VDE 0580
umgebungtemp./Ambient temp.:	+35°C	Kabelanschluß: Electric connection:	Gerätestecker DIN 43650 / Klemmk. DIN 43650 - plug / Terminal box
Ventilgehäuse: Body material:	./04../.. = Grauguß GG-25 / Cast iron ./05../.. = Stahlguß GS-C25 / Cast steel ./08../.. = Edelst.-1.4581/St. steel (AISI316Ti) ab DN65 Edelstahl 1.4408/ up to DN65 St. steel (AISI 316L)		
Dichtung/Seal:	NBR		

DN	Sitz Orifice Ømm	Kv-Wert Flow-rate m ³ /h	Standardtype Standard type PN16	max. Druck bei Magnettype max. pressure regarding solenoid type					
				.702	.322	.242	.272	.352	.402
15	15	7,0	A2301/0401/....	0-0,4	0-1,4*	-	-	-	-
20	20	9,0	A2302/0401/....	0-0,35	0-1*	-	-	-	-
25	25	12,0	A2303/0401/....	-	0-0,4	0-1*	-	-	-
32	32	18,0	A2304/0401/....	-	0-0,25	0-0,6*	-	-	-
40	40	26,0	A2305/0401/....	-	0-0,1	0-0,25*	-	-	-
50	50	38,0	A2306/0401/....	-	-	0-0,1	0-0,3*	-	-
65	65	75,0	A2307/0401/....	-	-	-	0-0,15*	-	-
80	80	89,0	A2308/0401/....	-	-	-	0-0,1	0-0,3*	-
100	100	125,0	A2309/0401/....	-	-	-	-	0-0,15*	-
125	125	240,0	A2310/0401/....	-	-	-	-	0-0,08*	-
150	150	370,0	A2311/0401/....	-	-	-	-	0-0,05*	-
200	200	625,0	A2312/0401/....	-	-	-	-	-	0-0,1*
Die Kv-Werte in der Tabelle gelten jeweils für das größte angegebene Magnetsystem! In each case, the flow-rate in the table are for the biggest mentioned solenoid system!*									
32	32	18,0	A2304/0401/....	-	-	0-1*	-	-	-
40	40	26,0	A2305/0401/....	-	-	0-0,5	0-1*	-	-
50	50	38,0	A2306/0401/....	-	-	-	0-0,6*	-	-
65	65	75,0	A2307/0401/....	-	-	-	0-0,3	0-0,8*	-
80	80	89,0	A2308/0401/....	-	-	-	0-0,2	0-0,6*	-
100	100	125,0	A2309/0401/....	-	-	-	-	0-0,3*	-
125	125	240,0	A2310/0401/....	-	-	-	-	0-0,2*	0-0,5*
150	150	370,0	A2311/0401/....	-	-	-	-	-	0-0,4*
200	200	625,0	A2312/0401/....	-	-	-	-	-	0-0,2*
250	250	950,0	A2313/0401/....	-	-	-	-	-	0-0,1*

Maßzeichnung Standardausführung
Dimensional drawing of standard type

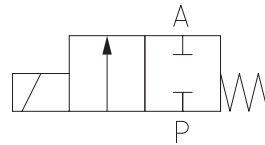
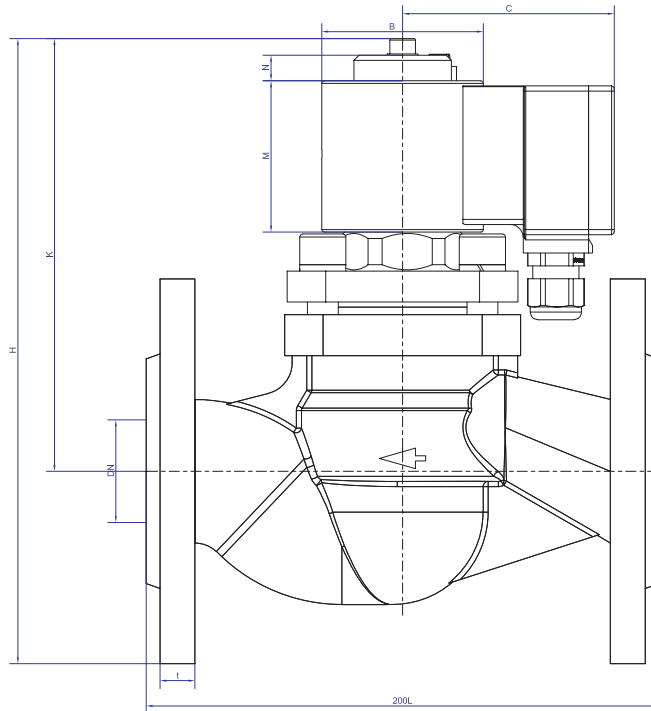

Schaltfunktion/Function:
in Ruhestellung gesperrt - NC.
normally closed - NC.

Anschlußplan / Connection diagram

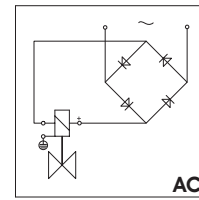
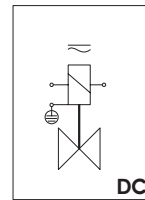

Für Gleichspannung.
For DC.

Mit vorgeschaltetem Gleichrichter
für Wechselspannung.
With rectifier for AC connection.

Erdung oder Schutzschaltung nach Vorschrift des zuständigen EVU.
Grounding or earthing of the protective circuit in accordance with
regulations of the responsible Electric supply company.

Absicherung entsprechend der Stromaufnahme vorsehen.
Appropriate protection according to power-consumption.

Magnet Solenoid	.702/.322		.322/.242			.242/.272		.272/.352			.402		
Type	2301	2302	2303	2304	2305	2306	2307	2308	2309	2310	2311	2312	2313
DN	15	20	25	32	40	50	65	80	100	125	150	200	250
B	45/63	45/63	63/77	63/77	63/77	77/105	77/105	105/145	105/145	105/145	130	130	130
C	66/76	66/76	76/82	76/82	76/82	82/95	82/95	95/120	95/120	95/120	160	160	160
H	213	223	278	290	305	353	393	470	500	545	743	780	983
K	165	170	220	220	230	270	300	370	390	420	600	610	780
L	130	150	160	180	200	230	290	310	350	400	480	600	730
M	50/59	50/59	59/70	59/70	59/70	70/90	70/90	90/145	90/145	90/145	293	293	293
N	10/16	10/16	16/20	16/20	16/20	20/25	20/25	25/20	25/20	25/20	20	20	20
t	14	16	16	16	16	18	18	20	22	24	26	26	34
Pg	11	11	11	11	11	11	11	11	11	11	11	11	11
kg	3,6	4,2	6,5	8	10	16,3	21,2	36	46,5	64,5	128	210	280

Alle Angaben sind freibleibend und unverbindlich / All technical specifications are without obligation!

Weitere Ventilausführungen

/

Optional extras

Stromlos geöffnet= NO
Non energised open= NO

Handbetätigung= HA
Manual override= HA

Dichtung= FKM, EPDM
Seal= FKM, EPDM

Halbautomatik= HU
Semi automatic= HU

Andere Durchflußmedien und Viskositäten
Varying medium and viscosity ranges

Öl- und fettfrei= OF
Free of oil and grease= OF (for oxygen applications)

Abweichende Temperaturen und Drücke
Varying temperature and pressure ranges

Buntmetallfrei= BF
Free of brass and bronze= BF

Stellungsanzeiger (Endschalter ab DN20 mit Magnet /.322)= EH
Position indicator (reed contact from DN 20 with solenoid /.322)= EH

Grundmengeneinstellung= GM
Base of volume adjustable= GM

Ex-Schutz= Ex II 2G EEx em II T4
Explosion proof= Ex II 2G EEx em II T4

Stückliste - Parts list

Baureihe A2310-2313 mit Magnet A542
 Type A2310-2323 with solenoid A542

- K1.1 Armatur / Valve body
- K2.1 Deckel / Cover
- *K3.1 Ventilspindel / Valve spindle
- *K3.2 Ventilteller / Valve head
- *K3.3 Dichtung / Sealing
- *K3.4 Führungsstern / Guiding insert
- *K3.5 Spindel / Spindle
- *K3.6 Mutter / Nut
- *K3.7 Überwurfmutter / Union nut
- K3.8 Mutter / Nut
- *K3.9 Dichtring / Sealing ring
- *K3.10 O-Ring / O-Ring
- K3.12 Mutter / Nut
- *K3.13 Stifte / Pin
- K3.14 Sechskantschraube / Hexagon head bolt
- K3.15 Stiftschraube / Stud bolt
- K3.16 Federring / Lock washer
- K3.17 M20x60-8.8 DIN 938 / M20x60-8.8 DIN 938
- K3.18 Ringmutter / Ring nut
- *K3.19 Feder / Spring
- K5.1 Tubus / Tube
- K6.1 Magnet / Solenoid

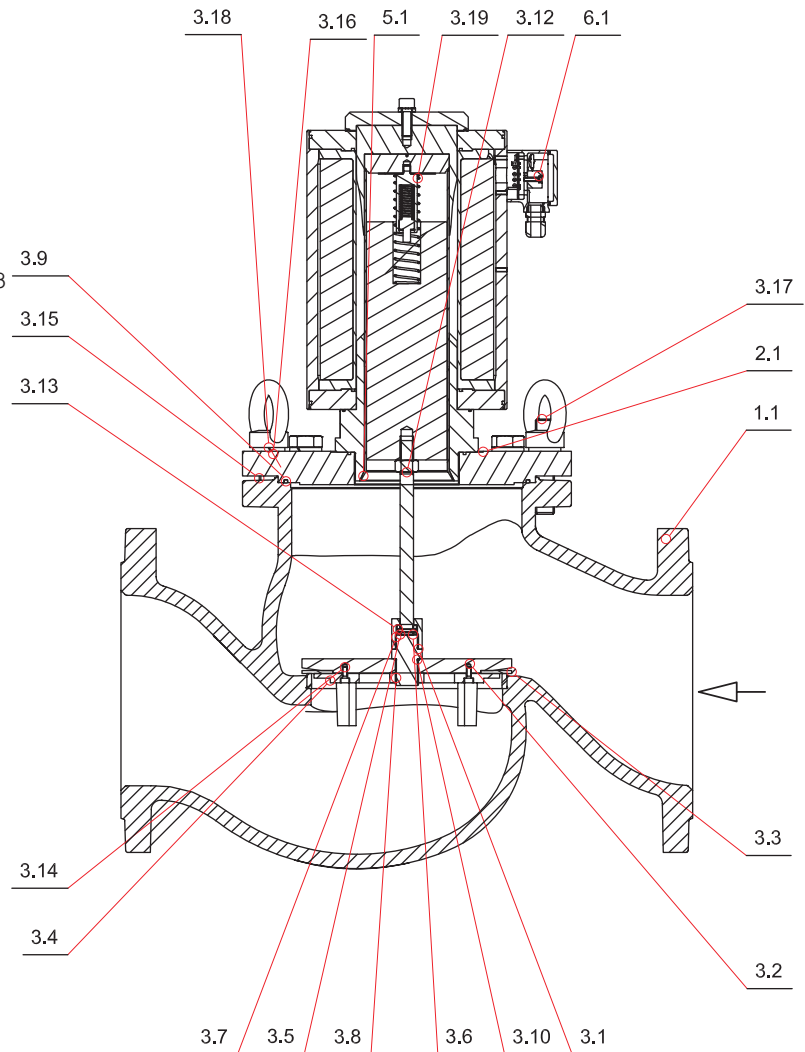

* = Bestandteil des Ersatzteilkäppchens
 (je nach Ausführung freibleibend)
 * = Parts of the service set. (These specifications
 are without obligation).

Bis DN40 sind die Positionen K3.1 K3.3 und K3.4
 ebenfalls Bestandteile des Ersatzteilkäppchens!
 Up to DN 40 the positions K3.1, K3.3 and K3.4 are
 also included in the service set!

Stückliste - Parts list

- K1.1 Armatur / Valve body
- K1.2 Sitz / Seat
- K2.1 Deckel / Cover
- *K3.1 Spindel / Spindle
- *K3.2 Scheibe / Disk
- *K3.3 Dichtung / Sealing
- *K3.4 Scheibe / Disk
- *K3.5 O-Ring / O-Ring
- *K3.6 O-Ring / O-Ring
- K3.7 Mutter / Nut
- *K3.8 Senkschraube / Countersunk bolt
- K3.9 Fedring / Lock washer
- K3.10 Zylinderschraube / Cylinder head screw
- *K3.11 Feder / Spring
- K3.12 Scheibe / Disk
- K3.13 Spindel / Spindle
- K3.14 Verschraubung / Connection
- *K3.15 Nutring / U-ring
- K3.16 Handrad / Handwheel
- K5.1 Tubus / Tube
- K6.1 Magnet / Solenoid

* = Bestandteil des Ersatzteilkäppchens
(je nach Ausführung freibleibend)
* = Parts of the service set. (These specifications are without obligation).

Ventiloptionen / Optional extras

Baureihe B2301-B2305 mit Handbetätigung - HA
Type B2301-B2305 with manual override - HA

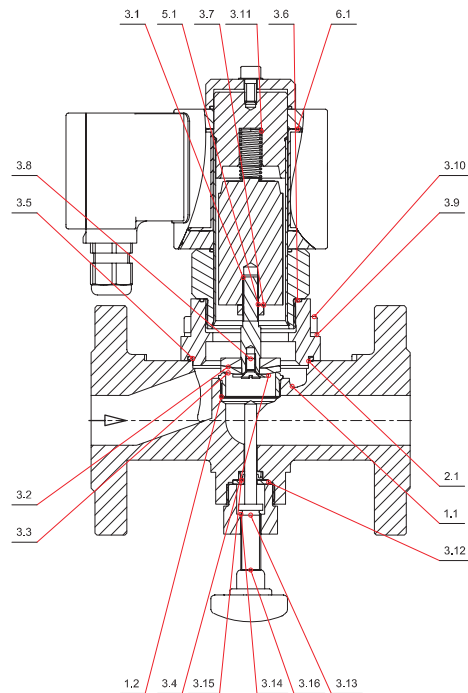

Stellungsanzeiger -EH und NO (ab DN20 mit Magnet / .322)
Position indicator -EH in NO design (from DN20 with solenoid / .322)

Stückliste - Parts list

- K1.1 Armatur / Valve body
- K2.1 Deckel / Cover
- *K3.1 Hauptventilspindel / Main valve spindle
- *K3.2 Ventilteller / Valve head
- *K3.3 Dichtung / Sealing
- *K3.4 Führungstern / Guiding insert
- *K3.5 Spindel / Spindle
- *K3.6 Mutter / Nut
- *K3.7 Überwurfmutter / Disk
- *K3.8 O-Ring / O-Ring
- *K3.9 O-Ring / O-Ring
- *K3.10 O-Ring / O-Ring
- K3.11 Mutter / Nut
- *K3.12 Stift / Pin
- K3.13 Zylinderschraube / Cylinder head screw
- K3.14 Federring / Lock washer
- K3.15 Feder / Spring
- K3.16 Verschraubung / Connection
- *K3.17 O-Ring / O-Ring
- K3.18 Spindel / Spindle
- K3.19 Schaltmagnet / Solenoid
- K3.20 Senkschraube / Countersunk bolt
- K3.21 Endschafter / Limit switch
- K3.22 Verschraubung / Connection
- K3.23 Klemmring / Clamping ring
- K5.0 Tubus / Tube
- K6.1 Magnet / Solenoid

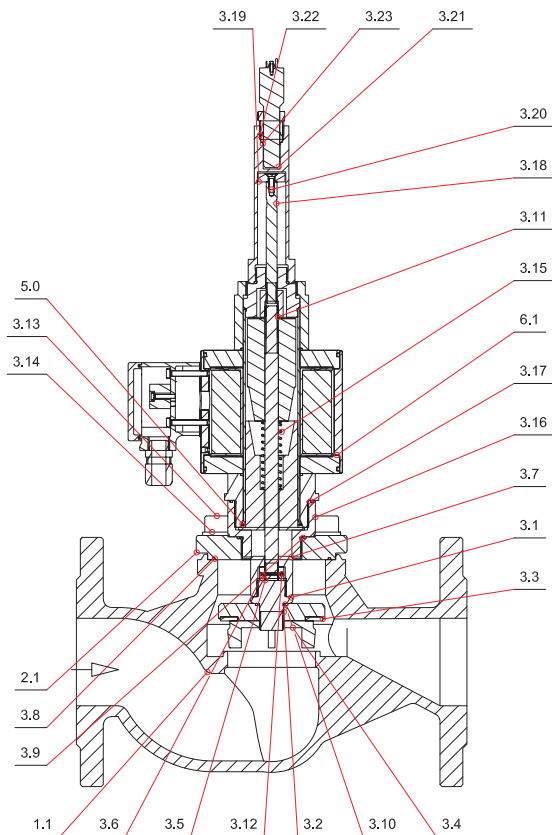

GSR Ventiltechnik GmbH & Co. KG
Postfach 2060 • D-32595 Vlotho • Im Meisenfeld 1 • D-32602 Vlotho
Telefon (05228) 779-0 • Telefax (05228) 779-190
E-mail: info@ventiltechnik.de http://www.ventiltechnik.de